

STRICTLY CONFIDENTIAL

FOR PHILIPS SERVICE

DEALERS ONLY



COPYRIGHT 1936

PHILIPS

SERVICE MANUAL

**SUPERHETERODYNE
ALL WAVE
MULTI-INDUCTANCE
BATTERY RECEIVER**

Type 714B

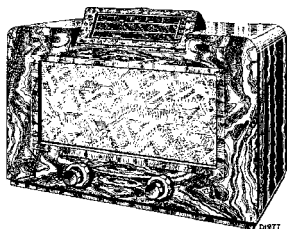
**GENERAL REMARKS.**

This battery receiver is designed for the following wavelengths:—

- A. 16.7— 51 metres (17.96—5.9 M.C.) Short wave.
B. [200— 585 „ (1,500—512 K.C.) Medium wave.
C. 725—2,000 „ (414—150 K.C.) Long wave.

The receiver is provided with delayed automatic volume control; variable tone filter; muting switch; plate aerial; sockets for fitting a gramophone pick-up; sockets for fitting an extra loudspeaker of high impedance.

The large knob on the left hand is for tone control, while the smaller knob is for the control of volume. The large knob on the right-hand side is the on/off and wave change switch, and the small knob is for varying the tuning condenser. The tuning control has a two-way speed adjustment. When the main control touches the stop at the back the receiver can be roughly tuned at normal speed, but as soon as the knob is adjusted in the opposite direction vernier tuning can be obtained.

The batteries used are as follows:—

- One 2-volt 20 A.H. Oldham accumulator, type ZL.G.3.
One combined 145½-volt H.T. and 10½-volt G.B. Ever-Ready Battery, "Portable 59."

DESCRIPTION OF CIRCUITS.

In the first place the circuits are described with the receiver adjusted for the medium wave range.

The aerial voltages which are received are inductively (S2) and capacitively (C15), coupled with S4. S4 forms, together with C1 and its trimming condenser C5, the first tuned circuit of the capacitively coupled band-pass filter, while the second tuned circuit consists of S6, C2, C14, with both circuits coupled by C17. The voltage across C2 is passed via C19 to the control grid of the modulator valve L1 (VP2). The tuned circuit of the oscillator valve L2 (PM1HL) comprising S10, C3, C7, C24, C22 is connected to the anode of L2 via the switch 3. The coil S12 is back-coupled to S10 and connected to the control grid of L2 through the switch, C26, R6. R5 is the grid leak. The difference in frequency of the two circuits described is passed via the anode of L1 to the coil S16, which is trimmed by C10 to the L.F. of 128 K.C.

This intermediate frequency voltage is again coupled to S17 and trimmed by C11. These two circuits constitute an inductively coupled band-pass filter. The intermediate frequency voltages are passed to L3 (VP2) and again amplified by the second L.F. band-pass filter S18, S19, C12, S20, C13, and then connected to the first diode anode of the valve L4 (TDD2A). The voltage developed across S20 is rectified, consequently forming a D.C. voltage with a super-imposed L.F. A.C. voltage.

The low frequency A.C. component voltage is passed to R8 (volume control) and coupled via the condenser C29 to the control grid of L4 via R9, R11 and further amplified by the special Q.P.P. transformer S21, S22, S23 which is coupled between L4 and L5 (QP22A).

A 2

The output from the valve is fed to an output transformer S24, S25, S26 to the permanently energised moving coil loudspeaker S27.

The I.F. voltage across S19 is passed via C31 to the second diode anode of L4, but when strong signals are received a large current will flow in the circuit, second diode anode, cathode, R13, R12, which will cause the voltage at the second anode to become more negative. This voltage is fed as an extra negative grid voltage to the grids of L3 and L1 via R7 and R1 respectively, and consequently reduces the amplification. The condensers C3 and C6 are fitted in the first H.F. section in order to suppress image frequencies. The coil S1 and condenser C4 in the aerial circuit forms an I.F. filter in order to prevent interfering signals at this frequency. The various grid bias and H.T. voltages are obtained from the various sections of the H.T. battery via the resistances which are decoupled by condensers.

For both long and short wavebands the I.F. section is the same as that for the medium waveband.

When the long waveband is switched in the following coil, condensers and resistances are switched in.

Aerial Circuit. S2, S3.

H.F. Circuit. S4, S5, C1, C5, C16, C17, S6, S7, C2, C14.

Oscillator. Anode circuits: S10, S11, C3, C22, C7, C8, C23, C24.

Grid circuit: S12, S13.

When the receiver is adjusted for short wave reception the following component parts are switched in.

Grid circuit of L1. S8, S9, C2, C18.

Oscillator. Anode circuit: S15, C25, R4.

Grid circuit: S14.

When the muting switch is pressed in with the knob on the left-hand side of the cabinet, C38 is connected in circuit. When the receiver is being operated for gramophone reproduction the voltage on the pick-up is across R8 and consequently this resistance operates as a volume control when the receiver is switched to "radio-gram."

Note.—The short wave side of the receiver has its oscillator frequency 128 K.C. lower than the frequency to which the H.F. circuits are tuned.

SPECIAL ADJUSTMENTS FOR QP22A.

In order that the two pentodes of the valve may be completely matched, particularly with respect to their quiescent anode currents, the auxiliary grid voltage must be adjusted. For this adjustment the valves are divided into five grades.

The two electrode assemblies are identified by the letter which is printed on the side of the base. These are marked "A" and "B" respectively. The five grades are lettered "P," "Q," "R," "S" and "T" and this marking is etched on the glass bulb immediately above the letters "A" and "B."

The H.T. battery which is supplied with the receiver is also marked with the same letters which are etched on the glass bulb to facilitate correct connection. The values of the auxiliary grid voltages and their respective letters are as follows:—

T	133.5 V.
S	128.0 V.
R	118.5 V.
Q	111.0 V.
P	103.5 V.

TRIMMING THE RECEIVER.

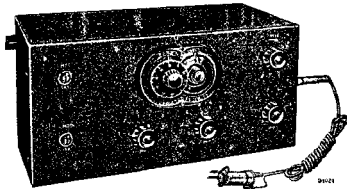

Fig. 1.

The receiver is equipped with trimming condensers so that any slight variation that may arise in the wiring of the circuit causing a capacity difference may be satisfactorily adjusted. If this is not done the amplification and selectivity will be considerably reduced owing to the tuning circuits not being "in step."

The I.F. stages are trimmed first, as this part of the circuit is utilised again for further balancing of the receiver.

When the primary winding of an I.F. transformer is trimmed the secondary must be damped by a resistance and, again, if the secondary is trimmed, the primary must be damped.

Damping resistances are necessary where tightly coupled circuits are involved in order to avoid two peaks in the resonance curve, and consequently they enable satisfactory trimming to be performed.

Where the various connecting points are difficult to reach, the damping resistance can be fitted to the plate or grid contacts, but in such cases a condenser of $0.1 \mu\text{F}$ must be placed in series in order to obviate short-circuiting the D.C. voltages.

The signal is passed to the control grid via a condenser of $32,000 \mu\text{F}$.

When this adjustment has been made and the appropriate signal passed to the receiver, with the volume control at maximum, the trimming of the H.F. circuits and the parallel trimming condenser of the oscillator can be adjusted.

Note.—Before altering the trimmers, it is necessary to soften the wax with a warm soldering iron.

It is important that the trimming condensers should be handled very carefully, otherwise it is possible that the connecting wires which are soldered to the heads of the adjusting screws may become loose.

The following instruments, etc., will be required for trimming:—

1. A service oscillator similar to Philips Type GM.2880 (see fig. 1).
2. An output meter similar to that which is fitted to the Philips Universal Measuring Board, fig. 4 or the special adaptation box, GM.2295, which can be fitted between the receiver to the trimmed and a moving coil instrument.
3. A 15° template Code No. 09.991.470 (Fig. 2).

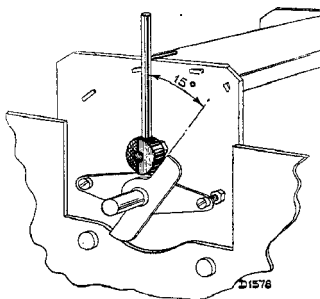

Fig. 2.

4. An auxiliary receiver or an aperiodic amplifier similar to GM.2404.
5. An insulated trimming screwdriver, Code No. 09.995.501 (see Fig. 3). (Prices and full particulars of test gear and tools can be obtained from the Service Department).

It will not be necessary to remove the chassis for trimming, the subsidiary baseplate can be removed and access to all the trimming condensers is then possible.

The following instructions are for trimming the complete receiver. The positions of the trimmers are shown at Fig. 10, on page 15.

The receiver must be trimmed with the valve L1 (VP2) which belongs to the receiver.

I.F. Trimming.

Switch the receiver to the long wave position, place tuning condenser to maximum, and short-circuit C3, (variable).

1. Apply a modulated signal of 128 K.C. via a condenser of $32,000 \mu\text{F}$ to the first grid of L3 (VP2).
2. Shunt S17 with $10,000 \mu\text{F}$ and trim C12, C13 to maximum output.
3. Remove the $10,000 \mu\text{F}$ from S17 and apply the signal to the first grid of L1 (VP2).
4. Damp S17 with $10,000 \text{ Ohms}$ and trim C10. Remove damping.
5. Damp S16 with $10,000 \text{ Ohms}$ with $0.1 \mu\text{F}$ in series, trim C11. Remove damping and repeat No. 4.
6. Trim C12.

TRIMMING THE H.F. AND OSCILLATOR CIRCUITS.

Switch the receiver to medium wave. Place 15° template in position and turn the variable condenser to the stop on the jig. Pass a signal of 1,442 K.C. (208 metres) to the aerial socket via the artificial aerial. Trim C7, C5 and C14 until maximum output is reached. Recheck to make sure that all the trimmers are correctly adjusted.

C 2

Switch the receiver to long wave. Place the variable to the stop on the 15° jig. Trim C8 for maximum output with a modulated signal of 760 metres (395 K.C.).

I.F. Aerial Filter.

Place a modulated signal of 128 K.C. to the aerial socket. Switch the receiver to long wave range, place the variable condenser to maximum and trim C4 to minimum output.

Image Frequency Filter.

Place a strong modulated signal of 1,000 K.C. (300 metres) to the aerial socket. Trim C6 for minimum output with the receiver carefully tuned to the second channel signal of approximately 403 metres.

Calibration.

If the receiver requires calibrating after repair readjust as follows:—

1. Switch the receiver to medium waveband.
2. Tune the receiver to a signal of 208 metres and adjust the pointer to the correct position.
3. Tune to 370 metres and check.
4. Tune to 510 metres and check.

The method of adjusting the position of the bracket of the drum disc is shown below.

340 M.	510 M.	
O.K.	too high	↑ or ↙
O.K.	too low	↘
too high	too high	←
too low	too low	→
too high	too low	↓
too high	O.K.	↓
too low	too high	↓
too low	O.K.	↑

Each time the bracket is displaced it will be necessary to retune to 208 metres.



Fig. 3.

HOW TO TRACE FAULTS.

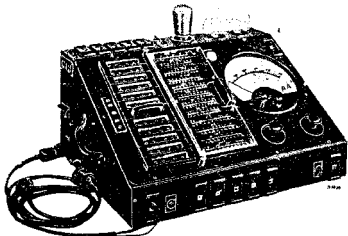

Fig. 4.

GENERAL REMARKS.

Fault finding will be considerably facilitated by the use of efficient testing apparatus. Attention is drawn to the Philips Universal Measuring Test-board (Fig. 4), which enables both A.C. and D.C. voltages and currents, capacities and resistances to be measured over a large number of ranges. The meter can also be used as an output meter when trimming, etc. Furthermore, particulars are given of the "point to point" method of testing a receiver, and it will be found that these particulars will considerably assist in locating faults quickly and accurately. The testing equipment operates from A.C. mains supplies, and full particulars and prices can be obtained from the Service Department.

METHOD OF TEST.

- I. Check all batteries before switching on, and then check all anode and grid voltages together with the voltage across the filament sockets of the valve holders with the set switched on. If there are no anode or auxiliary grid voltages in the second instance check C20, C36, C32 and screened anode leads.
- II. Equip the receiver with a known good set of valves (or a set of valves from a receiver which functions satisfactorily) and if necessary try another speaker.
- III. Try whether gramophone reproduction is possible, if it is not test as follows:—
 - A. **L5 has abnormal currents and voltages.**
 1. No anode current; defective switch contact, S24, S25 open-circuited, C36, C34, C32 short-circuited.
 2. Anode current too high; S22, S23, R19 open-circuited.
 3. Anode leads shorting to screening.
 - B. **L4 has abnormal currents and voltages.**
 1. No anode current; R20, R14 open-circuited. C34 shorted.
 2. R11, R9, R10, R16, R18 open-circuited. C30, C29 shorted.

- C. **L4 and L5 have normal current and voltages.**
 1. Defect in switch.
 2. S21, C29, C32, R8 open-circuited.
 3. C23, C28 short-circuited.

IV. Gramophone reception, but no radio reception.

- A. **L3 has abnormal current and voltages.**
 1. Defect in switch.
 2. Open-circuit S18, S19, S17.
 3. Open-circuit R7, R13, R22, R23.
 4. Short-circuit, C27, C42, C41.
- B. **L3 has abnormal currents and voltages.**
 1. Defect in switches.
 2. S10, S11, S15, R3 open-circuited.
 3. C23, C24 short-circuited.
 4. C26 short-circuited.
 5. R6, R5 open-circuited.
 6. S12, S13, S14 open-circuited.
 7. R4 open-circuited.
 8. C25 short-circuited.

C. **L1 has abnormal voltages and currents.**

1. Switch defective.
2. S16 open-circuited.
3. C19, C20 short-circuited.
4. R1, R7, R13 open-circuited.

D. **L1, L2 and L3 have normal current and voltages, but no wireless reception.**

1. No reproduction of a modulated I.F. signal of 128 K.C. when applied to the control grid of L1.
 - (a) S16, S17, S18, S19, S20 open or short-circuited.
 - (b) C10, C11, C12, C13 short-circuited.
2. No reproduction of a modulated H.F. signal applied to the control grid of L1.
 - (a) One of the coils or condensers in the oscillator section is open or short-circuited, i.e., C3, C27, C8, C26, S13, S14.

V. **Wireless and gramophone reception, but quality not satisfactory.**

- A. **Automatic volume control not functioning.**
 1. R12, R13, C31 open-circuited.
- B. **Receiver oscillates or distorts.**
 1. One of the decoupling condensers or the screening of the wiring is open-circuited, i.e., C34, C36, C20, etc.
 2. One of the decoupling resistances R23, R22, etc., open-circuited.

C. **Cabinet resonance.**

The usual cause of this is due to some loose part such as grid caps, screws, washers, etc. When the vibrating part has been detected a slight adjustment will generally cure the fault.

FAULT FINDING BY THE "POINT TO POINT" METHOD.

When the "point to point" method of testing is adopted in conjunction with a Philips Universal Testboard (Type 4256), a defect in the receiver may be quickly and systematically located.

In many cases it will be found that the chassis will not be required to be removed from the cabinet, and the following method of testing is suggested :—

- I. The receiver is connected to the recommended voltages, and is tested with its own valves on an outside aerial or service oscillator.
- II. Should the receiver not function, the valves should be replaced by another set of valves which are known to be in good working order, and also with another loudspeaker. If it is still found to be faulty it will be known that the valves and loudspeaker are in good order.
- III. A gramophone pick-up is connected to the receiver. If it is found that satisfactory reproduction can be obtained from this position then the chassis can be tested by working backwards, and subsequently placing an H.F. signal via a condenser of 0.1 μ F to the control grids of the various valves.
- IV. Should, however, no gramophone reproduction be possible or should the tests on the H.F. side of the receiver fail to give some result then the following tests should be made :—

1. A Philips Universal measuring Testboard (Type 4256) is then connected up and adjusted for resistance measuring (position 12, page 7). It is desirable that the positive pin of the test flex is sufficiently insulated and long enough so that the various parts of the chassis can be easily reached. The battery leads must be connected together.
3. The various resistances between the points, indicated in the accompanying table, and chassis, are measured by touching each contact with the positive pin. The reading obtained should then be compared with the value shown on the table.
P or A indicates that measurements should be taken between the gramophone pick-up or aerial sockets and earth.

21:22 indicates that a measurement should be taken between the points 21/22. It is possible for discrepancies of 10 per cent. to occur without the component part being necessarily defective.

4. When the resistances have been measured the testboard should be adjusted for capacity measurement, and the values specified in the table are checked.
5. All the circuits shown in the theoretical diagram are covered by these measurements, and, therefore, identification of the faulty part can easily be obtained by reference to the diagram.

The various contacts to the valve holders are systematically numbered in the following way.

- 1 & 2 = heaters, or filaments.
- 3 = control grid.
- 4 = metallising contact or diode.
- 5 = cathode.
- 6 = extra grid.
- 7 = a screening grid.
- 8 = anode.
- 9 = an extra grid (for instance, when employed in the octode).

From the table of measurements it will be clearly seen that the numbers are grouped according to the value of the resistance or capacities, so that all grid circuits (13, 33, etc.), are measured in position 9. On the other hand, all heater and cathode connections which are of low resistance are measured at position 12. In some measurements it may be necessary to adjust the wavelength switch. When this is necessary it is indicated in the table as

4 \times 16 S.M.L. or G.

The letters refer to the position of the wave-band switch.

When measurements are made on electrolytic condensers (resistance measurements), a deflection will, when the leak current is observed, be returned to a definite value. It may, however, be possible that the value is much too high owing to the condenser being defective, but it must be pointed out that if the receiver has not been in use for some considerable time, a similar type of reading will be obtained.

It is, therefore, desirable to check the quality of the electrolytic condensers carefully.

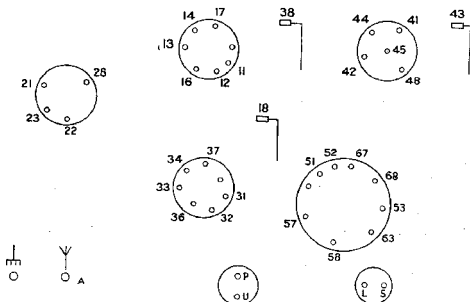

RESISTANCES.

12	4x					14	34	36	A _o	4x	11 / 21 / 31 / 41 / 51					P	17	L	57	67
	16	M	L	G	A					12	22	32	42	52						
	S 500	M 145	L 270	G 500	10	10	10	10	S 20	M 355	L 460	G 500	10	10	10	10	10	10	10	10
11	18	S	58	68																
	190	380	380	390																
10	23	28	37	18	48	38														
	280	190	250	400	175	400														
9	13	33	43	U	44	45	53	63	58	68										
	80	165	100	220	190	220	300	300	400	400										

CAPACITIES.

12																				
11	28	17	16	33	37															
	170	270	110	270	250															
10	38	58	68																	
	220	280	280																	
9	L																			
	350																			

All battery leads shorted to chassis for resistance tests.

REMOVING AND CHANGING OF PARTS.

Repairing and trimming will be greatly facilitated by the use of the Universal Chassis Holder (see Fig. 4a).

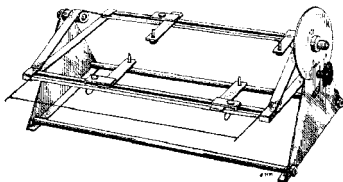

Fig. 4a

The chassis is secured to the holder by four screws and it can be rotated about its longitudinal axis and can also be secured in any predetermined position with the aid of the brake-disc at the side of the chassis holder. It can be adapted for chassis of varying dimensions. Special attention is drawn to the following points:—

1. Do not make any alteration in the wiring or screening plates.
2. Make sure that all the wires are kept clear of each other; not less than $\frac{1}{8}$ in.
3. Replace all spring washers, insulated material, etc., in their original places. If necessary rivets may be replaced by screws and nuts.
4. All moving parts unless otherwise stated may be greased with a little pure vaseline.
5. If necessary give the contacts a slight mechanical tension.
6. All soldering should be done as quickly as possible in order not to heat various parts.
7. All soldered joints to the leads of compound-treated condensers should be soldered $\frac{1}{8}$ in. from the compound in order to avoid overheating. Further, these condensers should be suspended clear of other wiring.
8. It is necessary to make quite sure that the resistances do not make contact with other parts which are in close proximity in order to avoid undue effects which may be caused by the heat emanating from the resistances. When the cabinet is placed bottom upwards (on a piece of felt or similar material) it is possible to reach the majority of components inside the chassis by removing the fibre sub-bottom plate. Practically all electrical faults and many mechanical ones can be remedied without taking the chassis from the cabinet. The chassis must never be lifted by the coils.

REMOVING THE CHASSIS FROM THE CABINET.

1. Remove the knobs from the front of the cabinet by releasing the grub screws.
2. Remove the four chassis screws from the underside of the cabinet.

3. Unscrew the cable eye and clips attached to the plate aerial. Also the earth lead attached to this screen.
 4. Unsolder the connections to the loudspeaker.
 5. Release the screw "A" (Fig. 12).
 6. Loosen the split nut "B". A special screw-driver (Code No. 09.991.770), can be supplied by the Service Department.
 7. Slacken off the screw cap "C" and also the end of the wire.
 8. Remove the screw "D."
- The chassis and scale drive can now be removed.

SECURING THE COILS AND TRIMMERS.

The coils are secured to the chassis by means of small flanges which form a part of the chassis. When the connections to the coil have been unsoldered the coil can be carefully removed from the chassis and a new coil fitted with the aid of a special tool.

Should, however, it be found that the flanges have broken off, the coil can be securely fixed with the aid of a clamping plate. This special type of clamp may be obtained from the Service Department. The clamping plate is fitted into the opening on the chassis and the flange can be readjusted so that the coil is firmly fitted.

DRIVING MECHANISM.

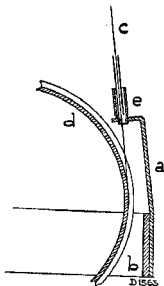

Fig. 5

The small brackets (a) which are rivetted to the large bracket (b) and into which the push cable (c) is fitted, must be positioned in such a manner relative to the drum (d) (see Fig. 5, page 8), so that the centre line of the aperture of the part (e) is at a tangent to the bottom of the groove in the drum.

Furthermore, the opening of the part (e) must lie exactly opposite the deepest part of the drum, otherwise the driving cable will tend to run against one of the side edges of the drum and slip off. The small part (e) must be soldered to the brackets (a) and care must be taken that these parts have no sharp edges, and also that solder does not run into them.

The driving cord can be supplied in suitable lengths, and should, prior to being used, be stretched for approximately one minute with a tension of approximately four pounds.

It is essential that the driving cord is secured to the teeth of the lever situated close to the pivot point. The length of the cord must, in every case, be such that the tension spring is completely closed. If the cord is found to be too long it may be shortened by tying a knot.

BOWDEN WIRES.

These wires can be supplied per metre. The inner wire will be found to be of two types. The thick type, A, is used for driving the variable selectivity coil, if used while the thin type is employed to drive the indicator pointer.

It is pointed out that a very slight kink in the bowden wire may cause rough running together with backlash, so it is important that care should be taken when adjusting this part of the receiver.

The bowden wire may easily be cut with pliers, but it is necessary to smooth down the ends with a file. Care should be taken so that no projections are left on the outside, otherwise difficulty will be experienced in obtaining a good fit.

The ends of the inner wire should always be soldered with acid-free flux so as to avoid any slackening.

WAVELENGTH SCALE POINTER.

When adjusting this part of the receiver care should be taken to make quite sure that the condenser reaches its maximum position before the indicator pointer. If this is not done there is a possibility of the inner wire becoming too slack and running off the drum.

VARIABLE CONDENSER VERNIER ADJUSTMENT.

Slipping may occur if the fibre bands become too smooth or if the resilient strips do not press hard enough. This may be remedied by turning the fibre bands round, or in the second case, by placing a slight set to the right-hand resilient strips.

WAVELENGTH SWITCH.

The wavelength switch consists of one or more units; a stop plate to determine the number of positions, spindle, springs.

One unit (Fig. 6), consists of a stationary ring called the stator, a rotor, contact springs (b) which are secured to the stator with small staples (c); one or more springs (d) which maintains the rotor in alignment with the stator and also various types of contact members and connections (a).

The stator is provided with 24 apertures distributed over a circle. On one side of the stator 12 contact springs may be fastened; one aperture is always kept open between the springs to allow of securing the contact springs on the other side so that a total of 12 contact springs may be secured on either side of the stator.

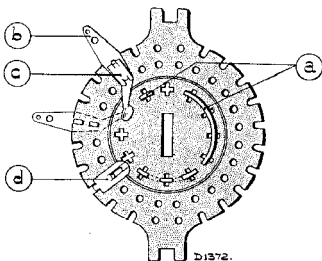

Fig. 6

EXPLANATORY NOTES OF THEORETICAL DIAGRAM.

In order to facilitate the reading of the diagram in connection with the wavelength switch, a brief explanation may be added.

The contact springs on the side of the stator that are fitted towards the stop plate are indicated as small circles in the outermost circles. When a contact spring is not fitted a dot is shown. Therefore, a total of 12 circles can be drawn in the outermost circle. In the innermost circle there are also 12 circles which indicate the contact springs on the opposite side of the stator.

Connections on the side of the rotor which turns towards the stop plate are shown as full lines in close proximity to the outermost circle. Those on the other side of the rotor are shown as a dotted line close to the innermost circle, while contact pieces are indicated as short lines between the inner and outer circle.

The rotor contacts cover one or more apertures, and form, on one side, a section of one circle.

The contacts are provided with small lips which penetrate into the aperture of the rotor and by means of which the contacts are secured. The lip on the opposite side is used for contact purposes.

It is essential, therefore, that the lip should be compressed so as to be perfectly flat.

DESCRIPTION OF CONNECTING PIECES IN THE LIST OF SPARE PARTS.

The connections (Fig. 7) can be made into various types, and a special method has been adopted so as to indicate quite clearly what type of connection is intended.

The first number specifies the number of apertures that are covered, while the other numbers indicate into which aperture the lip penetrates, from left to right.

For example, 41.4 denotes that four apertures are covered, and that, starting from left, the apertures 1 and 4 are made use of for securing purposes and also contact purposes on the other side.

Further, 5.2.3.5 denotes that five apertures are covered, and that the apertures 2.3.5 are used for securing and also for contacts on the other side.

G 3

In the list of component parts these connections are specified in this manner, and, therefore, it enables the indication of the part and its Code number to be determined very easily.

The contact springs of the rotor are supplied separately, and, therefore, it will be necessary for these to be secured by the service man. Special pliers can be supplied from the Service Department.

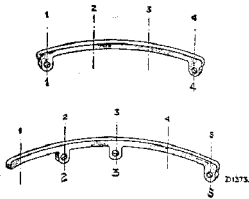

Fig. 7

LOUDSPEAKER.

Type No. 2315.

When repairs are made to a loudspeaker it is important that they are executed on a bench free from dust and also that good tools are used. On no account may the front and rear plates be removed, as the magnetism is likely to be affected.

It is important that the cover of the loudspeaker is replaced immediately the repair is finished.

The cone is centred by means of four small feelers, Code No. 09.990.840, and these are inserted in the air gap through the perforations of the spider.

When it is desired to renew a cone carrier or to re-centre the pole piece, a special template is necessary (see Fig. 8).

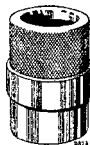

Fig. 8

Before repairing a loudspeaker make sure that there is a fault by trying another loudspeaker, and possibly another transformer, so as to ascertain that the fault does not originate in the receiver itself.

Where rattling or resonance is experienced, it is important to make sure that it is not due to some loose part in the cabinet. Alternatively, too tight or too loose connections to the speech coil or dirt in the air gap will cause rattling.

Note.—When the cone is moved upwards and downwards as shown in Fig. 9, no sound should be audible when held close to the ear.



Fig. 9

LIST OF SPARE PARTS, TOOLS, GAUGES, TEST GEAR, ETC.

When ordering spare parts or tools it is always necessary to specify :—

1. Code number.
2. Type number and serial number of the receiver.
3. Description of spare part, etc.

Fig.	Position.	Description.	Code No.
11	1	Cabinet	28.243.590
11	5	Knob, large (colour 005)	23.610.261
11	6	Knob, small (colour 005)	23.610.250
11	2	Escutcheon (colour 005)	23.684.095
11	2	Bottom piece, escutcheon (colour 005)	23.684.064
11	2	Diffusion screen	28.338.563
11	7	Trade mark disc	28.936.331
11	3	Station scale	28.704.120
11	4	Pointer	28.896.103
11	8	Wave-range indicator	28.944.533
12	11	Backplate	28.399.661
12	10	Flat spring (clip) for fixing backplate	25.673.860
12	9	Flat spring (clip) for fixing backplate (top)	28.750.040
12	13	Plug socket for pick-up and speaker	28.888.361
12	14	Plug socket plate for aerial and earth	28.888.371
12	18	Valve (grid) cap	28.855.310
13	25	Valveholder, 9 pin	28.838.600
13	26	Valveholder, 7 pin	28.225.420
13	24	Valveholder, 5 pin	28.225.410
13	27	Valveholder, 4 pin	28.225.900
13	28	Stator without contacts	28.934.580
13	29	Rotor without contacts	28.477.210
6	a.	Rotor contact, 1.1	28.904.161
6	a.	Rotor contact, 3.2	28.904.211
6	a.	Rotor contact, 4.1.4	28.904.182
6	a.	Rotor contact, 4.2.4	28.904.290
6	a.	Rotor contact, 4.1.3	28.904.221
6	b.	Stator contact	28.750.970
6	c.	Clip for stator contact	28.077.391
6	d.	Guide bracket	28.077.380
13	36	Mains switch	08.529.570
12	20	Inner control cable A (bowden)	33.635.590
12	20	Inner control cable B (bowden)	33.635.570
12	21	Outer control cable	33.635.050
12	22	Nipple for bowden cable	28.927.381
12	16	Flex (6 way)	28.499.200
12	23	Type plate (blank)	25.600.960
		Locking ring	28.445.821
		Paper washer	28.445.390
		Screen cap	28.253.260
12	12	Bush (under chassis)	28.890.300
12	15	Single pole plug	08.281.720
12	19	Cable tag for bowden cable	08.191.620
13	33	Driving cord	06.606.290
13	35	Spindle (volume control)	28.619.330
13	31	Spring } wavechange switch	28.751.890
13	32	Ball }	89.205.040
12	17	Cable tag for speaker flex	08.190.240
		Spring	28.730.462
13	30	Vernier unit	28.882.400

LIST OF SPARE PARTS, TOOLS, GAUGES, TEST GEAR, ETC.—continued.

Fig.	Position.	Description.	Code No.
TEST APPARATUS, TOOLS, GAUGES, ETC.			
1		Service oscillator, GM.2880	09.991.260
		Rectangular screwdriver	09.990.360
		Matching transformer, G.M.2295 for output indicator... ..	09.991.310
4		Universal testboard type 4256	09.991.030
4a		Universal testbench (jig)	09.991.380
		Lever for fixing coils	09.991.560
		Test prod	09.991.620
2		15° jig	09.991.741
8		Centring jig	09.991.530
		Pertinax feeler gauge	09.990.840
3		Insulated trimming screwdriver	09.991.501
		Special screwdriver	09.991.770

OHMIC RESISTANCE OF COILS

Designation.	Resistance in Ohms.	Code No.
S1 } C4 } 12-170 $\mu\mu\text{F}$	120	28.570.480
S2 } S3 } S4 } S5 } C5 } 2.5-30 $\mu\mu\text{F}$	24 90 5 43	28.570.540
S6 } S7 } 2.5-30 $\mu\mu\text{F}$	4.5 40	25.570.490
C14 } S8 } S9 } S10 } S11 } S12 } S13 } C7 } 2.5-30 $\mu\mu\text{F}$	0.05 0.05 10 25 4 8	28.587.590
C8 } 2.5-30 $\mu\mu\text{F}$		
S14 } S15 } S16 } S17 } C10 } 12-170 $\mu\mu\text{F}$	0.8 0.05 130 130	28.587.600
S18 } S19 } S20 } C12 } 12-170 $\mu\mu\text{F}$	35 95 130	28.570.700
S21 } S22 } S23 } S24 } S25 } S26 } S27 }	320 9,300 9,300 620 700 0.1 3.5	28.532.110 28.530.530 28.220.200

CONDENSERS.

Designation.	Condensers.	Code No.
C1	11—488 $\mu\mu\text{F}$	28.211.420
C2	11—488 $\mu\mu\text{F}$	
C3	11—488 $\mu\mu\text{F}$	
C4	see Coils	
C5	see Coils	
C6	2.5—30 $\mu\mu\text{F}$	28.211.320
C7	see Coils	
C8	see Coils	
C10	see Coils	
C11	12—170 $\mu\mu\text{F}$	28.211.310
C12	see Coils	
C13	12—170 $\mu\mu\text{F}$	28.211.310
C14	see Coils	
C15	10 $\mu\mu\text{F}$	28.206.340
C16	16000 $\mu\mu\text{F}$	28.199.010
C17	25000 $\mu\mu\text{F}$	28.199.030
C18	20 $\mu\mu\text{F}$	28.206.370
C19	100 $\mu\mu\text{F}$	TS.240.
C20	0.1 μF	28.199.090
C21	20 $\mu\mu\text{F}$	28.206.370
C22	20000 $\mu\mu\text{F}$	28.199.020
C23	764 $\mu\mu\text{F}$	28.193.240
C24	1615 $\mu\mu\text{F}$	28.193.250
C25	20000 $\mu\mu\text{F}$	28.199.020
C26	100 $\mu\mu\text{F}$	TS.240.
C27	0.1 μF	28.199.090
C28	100 $\mu\mu\text{F}$	28.206.270
C29	1000 $\mu\mu\text{F}$	28.198.890
C30	100 $\mu\mu\text{F}$	28.206.270
C31	100 $\mu\mu\text{F}$	28.206.270
C32	50000 $\mu\mu\text{F}$	28.199.060
C33	1000 $\mu\mu\text{F}$	28.198.890
C34	0.5 μF	28.198.270
C35	50000 $\mu\mu\text{F}$	28.199.060
C36	8 μF	28.182.370
C37	25 $\mu\mu\text{F}$	28.206.210
C38	10000 $\mu\mu\text{F}$	28.198.990
	16000 $\mu\mu\text{F}$	or 29.199.010
C39	1000 $\mu\mu\text{F}$	28.199.650
C40	6.4 $\mu\mu\text{F}$	28.206.320
C41	8000 $\mu\mu\text{F}$	28.198.980
C42	8000 $\mu\mu\text{F}$	28.198.980

RESISTANCES.

R1	1.25 M. Ohm	28.770.560
R2	50000 Ohm	28.773.870
R3	32000 Ohm	28.773.850
R4	32000 Ohm	28.773.850
R5	16000 Ohm	28.773.820
R6	40 Ohm	28.773.560
R7	0.5 M. Ohm	28.773.970
R8	0.5 M. Ohm	28.811.260
R9	0.2 M. Ohm	28.773.930
R10	1 M. Ohm	28.774.000
R11	0.2 M. Ohm	28.773.930
R12	1 M. Ohm	28.774.000
R13	0.32 M. Ohm	28.773.950
R14	25000 Ohm	28.773.840
R15	1 M. Ohm	28.774.000
R16	20000 Ohm	28.773.830
R17	5000 Ohm	28.773.770
R18	10000 Ohm	28.773.800
R19	0.2 M. Ohm	28.773.930
R20	8000 Ohm	28.773.790
R21	50000 Ohm	28.811.020
R22	4000 Ohm	28.773.760
R23	20000 Ohm	28.770.380

S: 1, 2, 3, 4, 6, 5, 7, 8, 9, 10, 11, 12, 13, 14, 15, 16, 17, 18, 19, 20, 21, 22, 23, 24, 25, 26, 27, 28, 29, 30, 31, 32, 33, 34, 35, 36, 37, 38, 39, 40, 41, 42, 43, 44, 45, 46, 47, 48, 49, 50, 51, 52, 53, 54, 55, 56, 57, 58, 59, 60, 61, 62, 63, 64, 65, 66, 67, 68, 69, 70, 71, 72, 73, 74, 75, 76, 77, 78, 79, 80, 81, 82, 83, 84, 85, 86, 87, 88, 89, 90, 91, 92, 93, 94, 95, 96, 97, 98, 99, 100, 101, 102, 103, 104, 105, 106, 107, 108, 109, 110, 111, 112, 113, 114, 115, 116, 117, 118, 119, 120, 121, 122, 123, 124, 125, 126, 127, 128, 129, 130, 131, 132, 133, 134, 135, 136, 137, 138, 139, 140, 141, 142, 143, 144, 145, 146, 147, 148, 149, 150, 151, 152, 153, 154, 155, 156, 157, 158, 159, 160, 161, 162, 163, 164, 165, 166, 167, 168, 169, 170, 171, 172, 173, 174, 175, 176, 177, 178, 179, 180, 181, 182, 183, 184, 185, 186, 187, 188, 189, 190, 191, 192, 193, 194, 195, 196, 197, 198, 199, 200, 201, 202, 203, 204, 205, 206, 207, 208, 209, 210, 211, 212, 213, 214, 215, 216, 217, 218, 219, 220, 221, 222, 223, 224, 225, 226, 227, 228, 229, 230, 231, 232, 233, 234, 235, 236, 237, 238, 239, 240, 241, 242, 243, 244, 245, 246, 247, 248, 249, 250, 251, 252, 253, 254, 255, 256, 257, 258, 259, 260, 261, 262, 263, 264, 265, 266, 267, 268, 269, 270, 271, 272, 273, 274, 275, 276, 277, 278, 279, 280, 281, 282, 283, 284, 285, 286, 287, 288, 289, 290, 291, 292, 293, 294, 295, 296, 297, 298, 299, 300, 301, 302, 303, 304, 305, 306, 307, 308, 309, 310, 311, 312, 313, 314, 315, 316, 317, 318, 319, 320, 321, 322, 323, 324, 325, 326, 327, 328, 329, 330, 331, 332, 333, 334, 335, 336, 337, 338, 339, 340, 341, 342, 343, 344, 345, 346, 347, 348, 349, 350, 351, 352, 353, 354, 355, 356, 357, 358, 359, 360, 361, 362, 363, 364, 365, 366, 367, 368, 369, 370, 371, 372, 373, 374, 375, 376, 377, 378, 379, 380, 381, 382, 383, 384, 385, 386, 387, 388, 389, 390, 391, 392, 393, 394, 395, 396, 397, 398, 399, 400, 401, 402, 403, 404, 405, 406, 407, 408, 409, 410, 411, 412, 413, 414, 415, 416, 417, 418, 419, 420, 421, 422, 423, 424, 425, 426, 427, 428, 429, 430, 431, 432, 433, 434, 435, 436, 437, 438, 439, 440, 441, 442, 443, 444, 445, 446, 447, 448, 449, 450, 451, 452, 453, 454, 455, 456, 457, 458, 459, 460, 461, 462, 463, 464, 465, 466, 467, 468, 469, 470, 471, 472, 473, 474, 475, 476, 477, 478, 479, 480, 481, 482, 483, 484, 485, 486, 487, 488, 489, 490, 491, 492, 493, 494, 495, 496, 497, 498, 499, 500, 501, 502, 503, 504, 505, 506, 507, 508, 509, 510, 511, 512, 513, 514, 515, 516, 517, 518, 519, 520, 521, 522, 523, 524, 525, 526, 527, 528, 529, 530, 531, 532, 533, 534, 535, 536, 537, 538, 539, 540, 541, 542, 543, 544, 545, 546, 547, 548, 549, 550, 551, 552, 553, 554, 555, 556, 557, 558, 559, 560, 561, 562, 563, 564, 565, 566, 567, 568, 569, 570, 571, 572, 573, 574, 575, 576, 577, 578, 579, 580, 581, 582, 583, 584, 585, 586, 587, 588, 589, 590, 591, 592, 593, 594, 595, 596, 597, 598, 599, 600, 601, 602, 603, 604, 605, 606, 607, 608, 609, 610, 611, 612, 613, 614, 615, 616, 617, 618, 619, 620, 621, 622, 623, 624, 625, 626, 627, 628, 629, 630, 631, 632, 633, 634, 635, 636, 637, 638, 639, 640, 641, 642, 643, 644, 645, 646, 647, 648, 649, 650, 651, 652, 653, 654, 655, 656, 657, 658, 659, 660, 661, 662, 663, 664, 665, 666, 667, 668, 669, 670, 671, 672, 673, 674, 675, 676, 677, 678, 679, 680, 681, 682, 683, 684, 685, 686, 687, 688, 689, 690, 691, 692, 693, 694, 695, 696, 697, 698, 699, 700, 701, 702, 703, 704, 705, 706, 707, 708, 709, 710, 711, 712, 713, 714, 715, 716, 717, 718, 719, 720, 721, 722, 723, 724, 725, 726, 727, 728, 729, 730, 731, 732, 733, 734, 735, 736, 737, 738, 739, 740, 741, 742, 743, 744, 745, 746, 747, 748, 749, 750, 751, 752, 753, 754, 755, 756, 757, 758, 759, 760, 761, 762, 763, 764, 765, 766, 767, 768, 769, 770, 771, 772, 773, 774, 775, 776, 777, 778, 779, 780, 781, 782, 783, 784, 785, 786, 787, 788, 789, 790, 791, 792, 793, 794, 795, 796, 797, 798, 799, 800, 801, 802, 803, 804, 805, 806, 807, 808, 809, 810, 811, 812, 813, 814, 815, 816, 817, 818, 819, 820, 821, 822, 823, 824, 825, 826, 827, 828, 829, 830, 831, 832, 833, 834, 835, 836, 837, 838, 839, 840, 841, 842, 843, 844, 845, 846, 847, 848, 849, 850, 851, 852, 853, 854, 855, 856, 857, 858, 859, 860, 861, 862, 863, 864, 865, 866, 867, 868, 869, 870, 871, 872, 873, 874, 875, 876, 877, 878, 879, 880, 881, 882, 883, 884, 885, 886, 887, 888, 889, 890, 891, 892, 893, 894, 895, 896, 897, 898, 899, 900, 901, 902, 903, 904, 905, 906, 907, 908, 909, 910, 911, 912, 913, 914, 915, 916, 917, 918, 919, 920, 921, 922, 923, 924, 925, 926, 927, 928, 929, 930, 931, 932, 933, 934, 935, 936, 937, 938, 939, 940, 941, 942, 943, 944, 945, 946, 947, 948, 949, 950, 951, 952, 953, 954, 955, 956, 957, 958, 959, 960, 961, 962, 963, 964, 965, 966, 967, 968, 969, 970, 971, 972, 973, 974, 975, 976, 977, 978, 979, 980, 981, 982, 983, 984, 985, 986, 987, 988, 989, 990, 991, 992, 993, 994, 995, 996, 997, 998, 999, 1000.

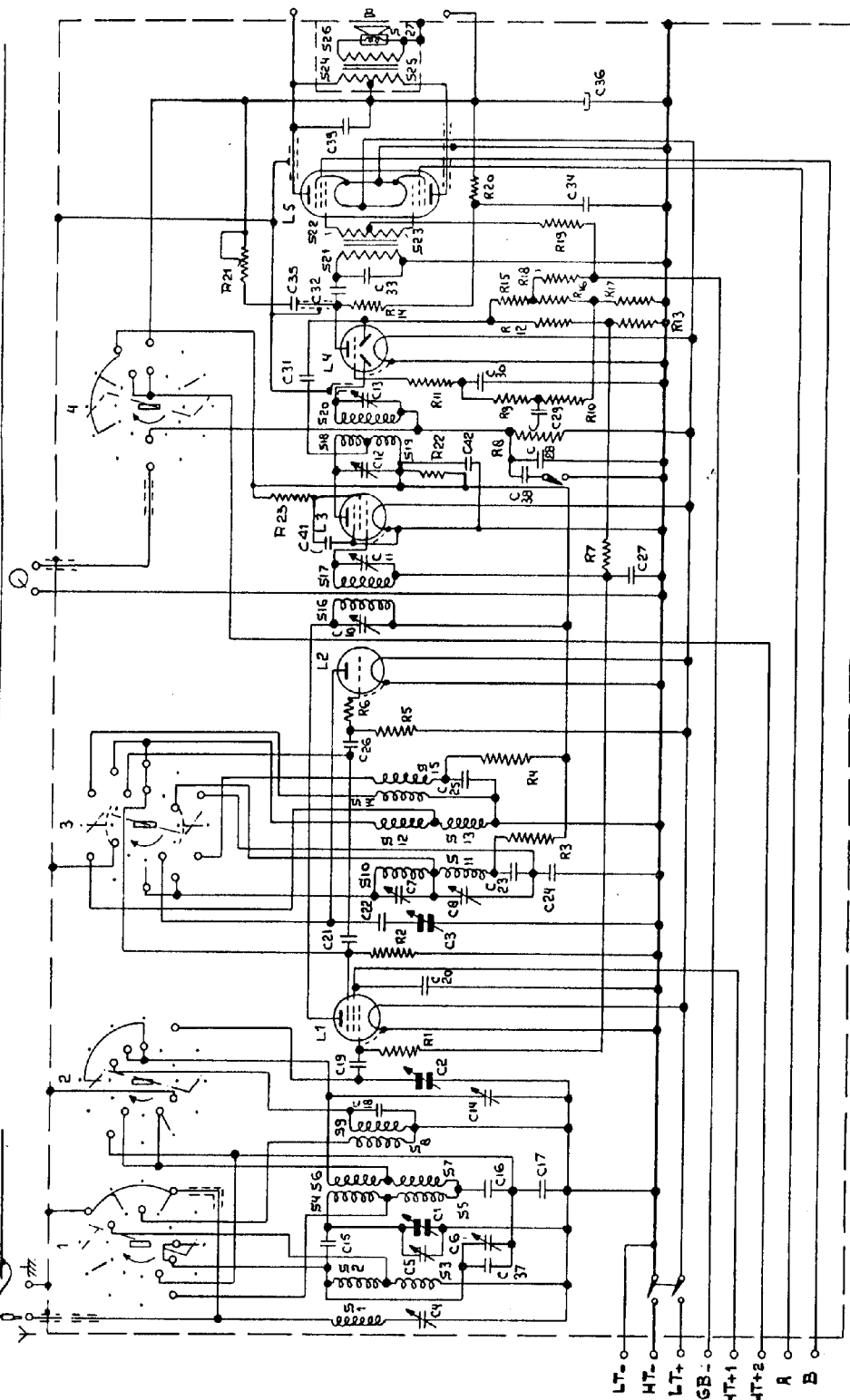

VALVES.

L1	L2	L3	L4	L5
VP2	PM1HL	VP2	TDD2A	QP22A

VALVE VOLTAGES AND CURRENTS.

	L1	L2	L3	L4	L5	
Va	145	70	135	100	145 (A & B)	Volts
Vg*	115	—	130	—	*103-133 (A & B)	Volts
Ia	1.0	1.8	1.6	0.8	.5-2.0	mA
Ig*	0.3	—	0.3	—	0.02-0.20	mA

* Varies with grade of valve.
Total filament current = 1.05 amp.

The voltages are measured with voltmeters having a resistance of 2000 Ohms per volt. Moving coil voltmeters give readings which depend upon the resistance used and the current consumption of the meter itself. The values given are the mean of several measurements, therefore, some readings obtained may differ appreciably, due to the tolerances of the components as well as the valves. Before finally deciding that a valve is defective it is recommended that a replacement test with the same type of valve is made.

S:	22,	21,23,	20, 19, 18,	16,	17,	8,	2, 4, 5, 9, 6, 7, 11, 14, 15, 13, 110, 2, 13,
C:	36, 33,	34,	32, 39, 29, 35	30,	31, 38, 13, 12,	41, 19,	17, 26, 27, 10, 12, 32, 37, 11,
R:	20,	14,	9, 10, 11, 19,	21, 18, 16, 8, 14, 2, 13, 17,	7,	22,	3, 23, 5, 2, 1,
							6,
							4,

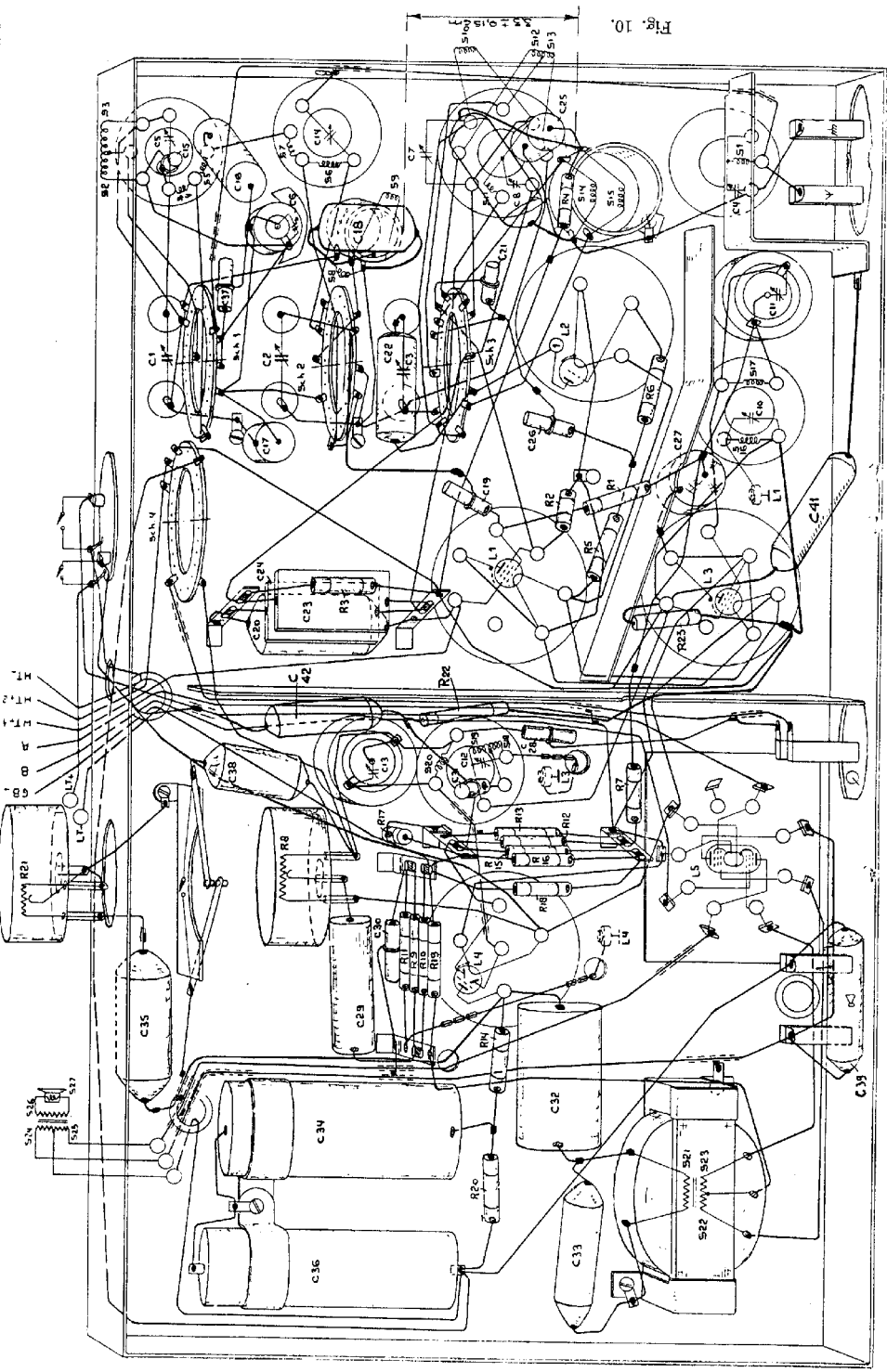

Fig. 10.

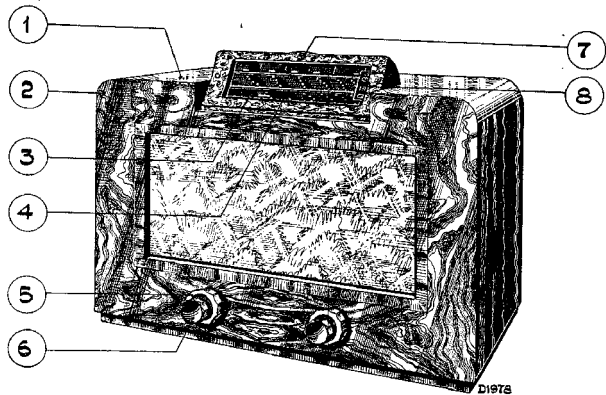

Fig. 11

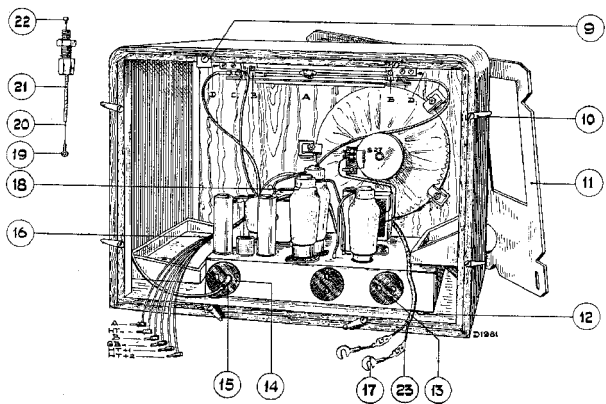

Fig. 12